

**MODEL/S**  
**GGSRC60**  
**GGSRC90**



ESSENTIALS FOR LIFE

# **User Manual**

**60/90cm Canopy  
Rangehood**

**SÔLT**

# Welcome

Congratulations on purchasing your new Canopy Rangehood! The Sôlt brand is proudly distributed within Australia by Residentia Group Pty Ltd.

## Residentia Group

–  
Head Office.  
165 Barkly Ave  
Burnley  
Victoria 3121  
Australia

–  
ACN.  
600 546 656

–  
Online.  
[residentia.group](http://residentia.group)

Please refer to the warranty card at the rear of this manual for information regarding your product's parts and labour warranty, or visit us online at [www.residentia.group](http://www.residentia.group)

At Residentia Group, we are customer obsessed and our Support Team are there to ensure you get the most out of your appliance. Should you want to learn more about your rangehood features, and importantly taking care of your appliance when cleaning, our Support Team are here to help.

You can use our online Support Centre at anytime by visiting <http://support.residentiagroup.com.au>, or you can contact us via calling us on 1300 11 HELP (4357).

It is important that you read through the following use and care manual thoroughly to familiarise yourself with the installation and operation requirements of your appliance to ensure optimum performance.

Again, thank you for choosing an Sôlt appliance and we look forward to being of service to you.

Kind Regards,  
The Residentia Team

<b>Contents</b>	<b>2</b>	<b>Welcome</b>
	<b>4</b>	<b>Safety Instructions</b>
	<b>5</b>	<b>Specifications &amp; Components</b>
	<b>6</b>	<b>Controls</b>
	<b>6</b>	<b>Installation Requirements</b>
	<b>9</b>	<b>Cleaning &amp; Maintenance</b>
	<b>9</b>	<b>Technical Data</b>
	<b>10</b>	<b>Troubleshooting</b>
	<b>11</b>	<b>Purchase Details</b>
	<b>12</b>	<b>Attach Your Receipt</b>
	<b>14</b>	<b>Warranty Information</b>

# Safety Instructions

This rangehood must only be installed in accordance with the instructions provided. Incorrect installation may cause harm to persons, damage property and void the product's warranty. This rangehood complies the safety standard AS/NZS60335.2.31 and AS/NZS 60335.1

## Important

Please ensure that you read the entire instructions before beginning the installation of your rangehood.

## Warning

All electrical work must be done in accordance with local and national electrical codes as applicable and should be undertaken by licenced and qualified persons only.

- This rangehood is designed for domestic household use only.
- This appliance is not intended to be used by children, or persons with reduced physical, sensory or mental capabilities, or lack of experience and knowledge, unless they have been given supervision or instruction concerning the use of the rangehood by a person responsible for their safety.
- Young children should be supervised to ensure that they do not play with the appliance.
- You must read the instructions concerning the method and frequency of cleaning.

## Important!

There is a risk of fire if cleaning isn't carried out in accordance with the instructions.

- Never flambé under the rangehood.
- Exhaust air must not be discharged into an existing flue which is used by other appliances for exhausting fumes.
- If the power supply cord of this rangehood is damaged in any way, it must only be replaced by one of our authorised service agents. Please call the Support Team on 1300 11 4375 for further assistance.
- Your new rangehood is guaranteed against electrical or mechanical defects, subject to certain exclusions that are noted in the Warranty Terms and Conditions (at the rear of this user manual). The foregoing does not affect your statutory rights.
- The use of this rangehood for any other purpose or in any other environment, without our express agreement, will invalidate any warranty or liability claim.
- No modifications to the appliance are permitted.
- Repairs may only be carried out by authorised service agents.
- Cleaning of the rangehood should be carried out on a regular basis.
- There shall be adequate ventilation of the room when the range hood is used at the same time as appliances burning gas or other fuels (not applicable that only discharge the air back into the room).
- The air must not be discharged into a flue that is used for exhausting fumes from appliances burning gas or other fuels.
- Regulations concerning the discharge of air have to be fulfilled.

## Unpacking

During transportation, protective packaging was used to protect the appliance against any damage. After unpacking, please dispose of all elements of packaging in a way that will not cause damage to the environment. All materials used for packaging the appliance are environmentally friendly; they are 100% recyclable and are marked with the appropriate symbol.

## Caution!

During unpacking, the packaging materials (polythene bags, polystyrene pieces, etc.) should be kept out of reach of children.

### Disposal of the appliance

Old appliances should not simply be disposed of with normal household waste, but should be delivered to a collection and recycling centre for electric and electronic equipment. A symbol shown on the product, the instruction manual or the packaging shows that it is suitable for recycling.

Materials used inside the appliance are recyclable and are labelled with information concerning this. By recycling materials or other parts from used devices you are making a significant contribution to the protection of our environment.

Information on appropriate disposal centres for used devices can be provided by your local authority.

## SPECIFICATIONS & COMPONENTS

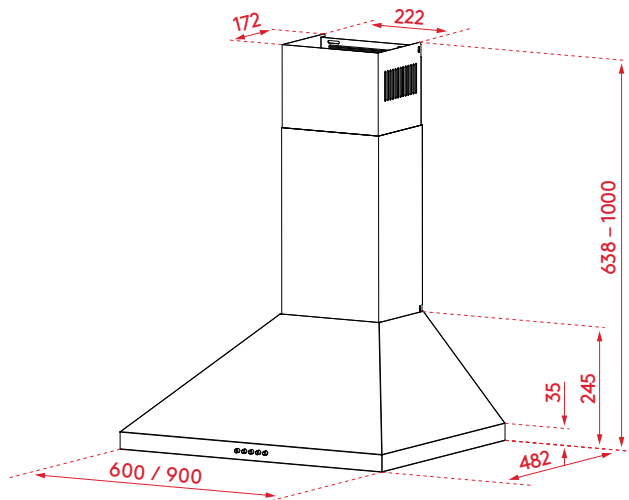

### GGSRC60







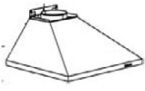

Product dimensions (W,D,H):  
600mm, 480mm, 638–1000mm  
Weight: 7.5kg  
Extraction: 550m<sup>3</sup>/hr extraction  
Other features:  
– 3 speed push button control  
– 2 × LED lights  
– 2 × Aluminium filters

### GGSRC90

Product dimensions (W,D,H):  
900mm, 480mm, 638–1000mm  
Weight: 10.2kg  
Extraction: 550m<sup>3</sup>/hr extraction  
Other features:  
– 3 speed push button control  
– 2 × LED lights  
– 3 × Aluminium filters

### Rangehood components

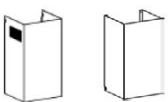
Your Canopy Rangehood is supplied with:

1 x Rangehood		1 x Wall bracket ("hook") for the rangehood	
1 x Expandable 150mm ducting adapter		1 x Wall bracket for inside chimney pieces	
1 x packet of fasteners, wall plugs and safety screws		1 x Outside chimney bracket	
2 x Stainless steel flue pieces (upper and lower)		1 x User Manual	

# Controls

Your Canopy Rangehood features push button controls (Fig. 1) with three speed levels of extraction.

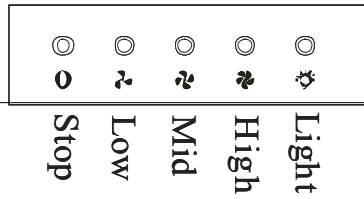

Fig. 1

- Push the 'Low' button, and the rangehood will operate at low speed.
  - Push the 'Mid' button, and the rangehood will operate at a medium speed.
  - Push the 'High' button, and the rangehood will operate at a high speed.
  - Push the 'Light' button and the two lights will come on. To turn the lights off, simply push the 'Light' button again.
  - To switch the rangehood motor or light off, simply press the stop button a second time.
- It's important to carefully read the following installation instructions before beginning the installation of your rangehood.**

## INSTALLATION REQUIREMENTS

### Typical installation tools required

You'll most likely require the following tools/equipment (not supplied) for the installation of your rangehood.

- Electrical drill
- Tape Measure
- Screw-driver
- Spirit Level

### If ducting your rangehood, you'll also most likely require:

- Jig saw
- Ladder
- Duct-tape
- Ducting

### Important installation safety notes:

- Always switch the power off prior to beginning the installation.
- Stainless steel is very easily damaged during installation. Wherever possible, protect the rangehood with the cardboard box or plastic wrap during the installation.
- For safety reasons, this Rangehood must be earthed.
- A power point must be located within 1.5m of the power cord exit from the rangehood, and it should be always accessible to allow isolation from power during cleaning or maintenance.
- A 150mm round ducting adapter is supplied, however all other ducting accessories are not.
- All ducting must comply with building codes and local requirements.
- If you are re-circulating the air, rather than ducting, please ensure that the side outlet grilles are not obstructed in any way as this will affect the efficiency of the rangehood.
- Ensure that the rangehood is mounted in a level position, both horizontally and vertically. This is essential to ensure the rangehood operates correctly and prevents grease build up at one end.

### WARNING!

All electrical work associated with the installation of this rangehood must be carried out by a licensed electrician. This rangehood must be correctly installed by a suitably qualified person in strict accordance with all applicable rules and regulations and following the instructions in this manual.

Do not try to install the rangehood yourself; doing so will expose you to danger and void the warranty. Improper installation, adjustment, alteration or service can cause injury or damage. We decline any responsibility for injury or damage, to persons or property, as a result of improper installation.

## Ducting options

Before beginning the installation of your rangehood, the method of ducting should be considered and selected. The guide below illustrates the various ducting options.

### Note:

This rangehood can be operated in recirculation mode where required, although it is recommended to duct wherever possible.

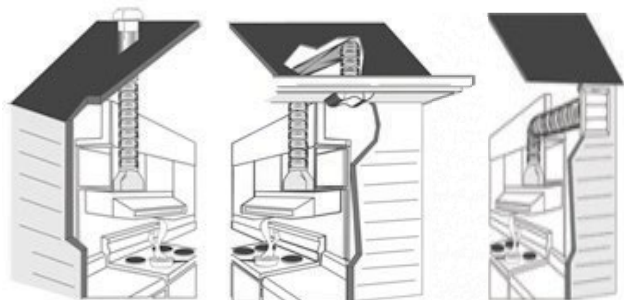

Fig. 2

Fig. 3

Fig. 4

- Straight up and through your tiled or metal roof. (Fig. 2)
- Into your ceiling cavity and then vented through your eaves. (Fig. 3)
- Through your wall (Fig. 4)

Further to your various ducting options, below are some tips on how to correctly duct your rangehood:

- Always use correctly sized ducting:  
DO NOT reduce the size of the ducting
- Always use solid ducting
- Always use non-flammable ducting
- Always duct to the outside atmosphere
- Do not use flexible ducting
- Do not duct into the ceiling space:  
always vent to the outside atmosphere.
- Avoid sharp 90 degree bends as much as possible, use 45 degree bends instead wherever possible
- Duct to the outside atmosphere using the shortest duct run possible
- Use cylindrical ducting whenever possible

## Positioning the rangehood:

### Installation heights

- Over gas and electric cookers, we recommend our rangehoods to be mounted at a height of between 600-800mm above the cooking surface.
- Electric cooktops must have a minimum height of 600mm from the underside of the rangehood to the cooktop face.
- Gas cooktops must have a minimum of 650mm from the burner to the underside of the rangehood.
- Gas Regulations require the filters of the rangehood to be at least 1200mm above the cooking surface when used over open flame grillers or barbecues.\*

\* We do not recommend this rangehood for outdoor use or being installed above barbecues/open flame grillers.

### Installing the rangehood

- Once the installation height has been determined, use the fasteners and wall plugs to install the mounting bracket (hook) on to the wall ensuring that it's secured in a level position. The mounting bracket connects to the canopy at the top (i.e. where the chimney connects into the canopy). Also using the fasteners and wall plugs, install the wall bracket for the chimney pieces. (Fig. 5)
- Using the screws provided, attach the expandable 150mm ducting adapter to the canopy. With the two Chimney pieces together, fix the "outside chimney" bracket onto the outside chimney (flue) piece. Ensure that the inner chimney piece can move freely inside. Now attach the chimney pieces to the canopy. (Fig. 6)
- Lift the canopy (including the chimney pieces) on to the wall bracket (hook). (Fig. 7)
- Adjust the height of the inside chimney piece and fix into place with the screws. After adjusting the position of the canopy, fix into place with the safety screws (Fig. 8) into the wall (you'll need to remove the grease filters first).

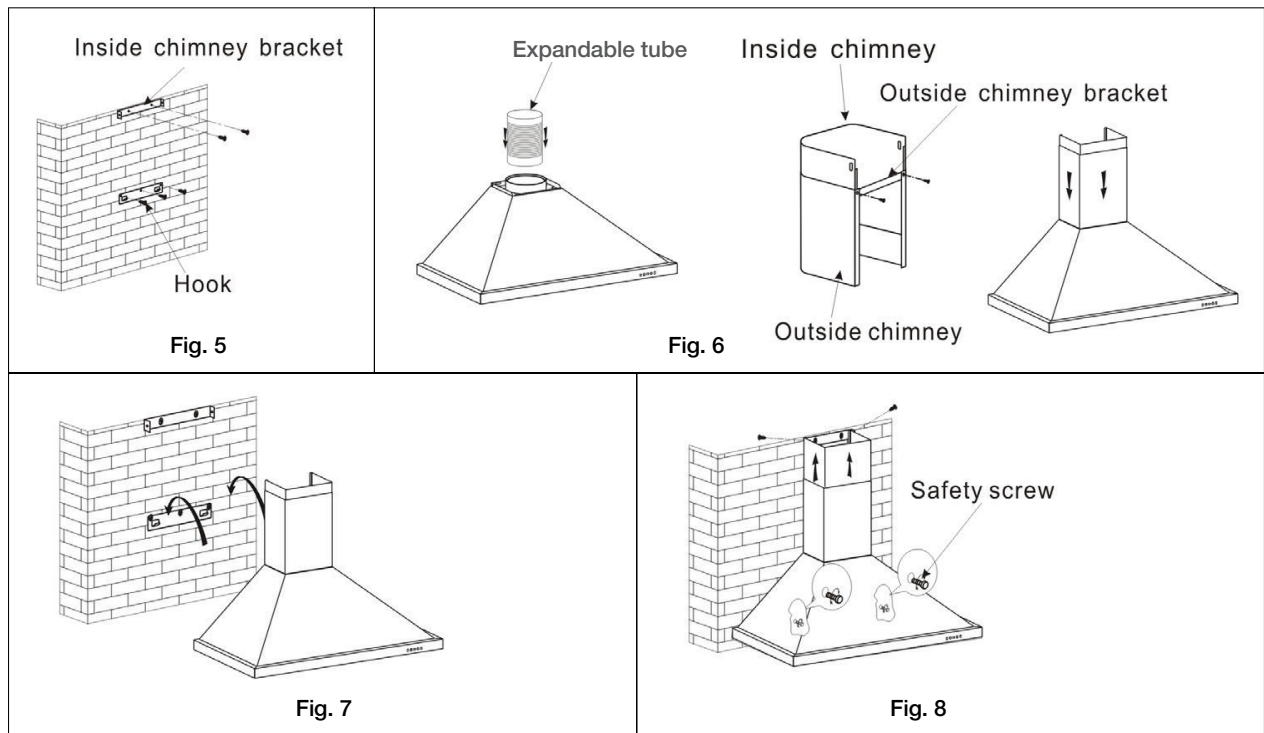



# Cleaning & Maintenance

## Cleaning the grease filters

Keeping this filter clean will keep the rangehood extraction performance at an optimum. Please strictly follow the guidelines below.

- The grease filter is made of high-density stainless steel. Please ensure you never use a corrosive detergent during cleaning.
- Method 1: Put the filter into 40–50°C clean water with a small amount of regular dishwashing liquid, and soak for 2–3 mins. Wear gloves and clean with a soft brush. Please do not apply too much pressure, as the filter is delicate and will damage easy.
- Warning! Your rangehood grease filters can not be washed in your dishwasher, or the protection coating would be cleaned away.

## Cleaning the cooker hood

To protect the main body of your rangehood from corrosion or stains, the cooker hood should be cleaned with hot water with a non-corrosive detergent every two months. For stubborn stains or marks, you can try using a specific stainless steel cleaner available from most supermarkets.

### Warning!

Please do not use a corrosive detergent, or abrasive cloths, as it will damage the body.

- Keep the motor and other spare parts free from water, as this will cause damage to the appliance.
- Before cleaning the rangehood, always switch the power off at the outlet and unplug the rangehood.
- If your rangehood has a damaged plug or cord, please ensure your rangehood remains unplugged and contact After Sales Support for further assistance. Any electrical work should only be completed by a suitably licenced and authorised person.
- If you're using a carbon filter, it should never be exposed to heat.

# Technical Data

---

Electrical details: Rated Voltage: AC 220 – 240V 50/60Hz | Rated Power: 104W

---

# Troubleshooting

## Operation in case of emergency

In the event of an emergency you should:

- Switch off all rangehood controls.
- Switch the rangehood off at the power outlet and immediately unplug.
- Call After Sales Support on 1300 11 HELP (4357).

Some minor faults can be fixed by referring to the instructions given in the Troubleshooting section below.

## Important!

If your appliance appears to be operating incorrectly, then you should disconnect it from your electrical supply and then contact After Sales Support on 1300 11 HELP (4357).

## Warning!

Do not attempt to repair the rangehood yourself.

Please note that if an engineer is asked to attend whilst the product is under warranty and finds that the problem is not the result of an appliance fault, then you may be liable for the cost of the call out charge.

The appliance must be accessible for the engineer to perform any necessary repair. If your appliance is installed in such a way that an engineer is concerned that damage will be caused to the appliance or your kitchen, then they will not complete a repair. This includes situations where the rangehood has been tiled in or sealed in with a sealant.

Please refer to the conditions of that appear on the warranty card at the rear of this user manual.

Fault:	Common Cause:	Common Solutions:
The lights work, however the motor does not work	The motor is blocked or jammed.	Call After Sales Support for further guidance.
	The capacitor is damaged.	Call After Sales Support for further guidance.
Neither the lights or the motor works	Beside the above mentioned, check the following:	
	Light globes are damaged or blown	Call After Sales Support for further guidance.
	The power cord is loose.	Ensure that the rangehood is correctly plugged in and the power outlet is switched on.
The rangehood is vibrating against the wall	The rangehood canopy is not fixed to the wall correctly.	Ensure that the internal safety screws have been used and are tight.
Insufficient suction	The distance between the rangehood and your cooktop is too great.	Have your installer re-adjust the installation position, ensuring that the minimum distances are observed as per the building code.

# Purchase Details

For future reference, please record the following information which can be found on the rating plate and the date of purchase which can be found on your sales invoice.

---

## STORE DETAILS

---

STORE NAME | \_\_\_\_\_

ADDRESS | \_\_\_\_\_

TELEPHONE | \_\_\_\_\_ PURCHASE DATE | \_\_\_\_\_

---

## PRODUCT DETAILS

---

MODEL NO. | \_\_\_\_\_

SERIAL NO.\* | \_\_\_\_\_

**Attach your receipt  
to this page**



**This page  
is intentionally  
left blank**

# Warranty Information

## WARRANTY TERMS & CONDITIONS CANOPY RANGEHOOD

This document sets out the terms and conditions of the product warranties for Residentia Group Appliances. It is an important document. Please keep it with your proof of purchase documents in a safe place for future reference should you require service for your Appliance.

### 1. IN THIS WARRANTY

- (a) 'acceptable quality' as referred to in clause 10 of this warranty has the same meaning referred to in the ACL;
  - (b) 'ACL' means Trade Practices Amendment (Australian Consumer Law) Act (No.2) 2010;
  - (c) 'Appliance' means any Residentia Group product purchased by you accompanied by this document;
  - (d) 'ASR' means Residentia Group authorised service representative;
  - (e) 'Residentia Group' means Residentia Group Pty Ltd of 165 Barkly Ave, Burnley VIC 3121, ACN 600 546 656 in respect of Appliances purchased in Australia;
  - (f) 'major failure' as referred to in clause 10 of this warranty has the same meaning referred to in the ACL and includes a situation when an Appliance cannot be repaired or it is uneconomic for Residentia Group, at its discretion, to repair an Appliance during the Warranty Period;
  - (g) 'Warranty Period' means:
    - (i) where the Appliance is used for personal, domestic or household use (i.e. normal single family use) as set out in the instruction manual, the Appliance is warranted against manufacturing defects for 24 months, following the date of original purchase of the Appliance;
  - (h) 'you' means the purchaser of the Appliance not having purchased the Appliance for re-sale, and 'your' has a corresponding meaning.
2. This warranty only applies to Appliances purchased and used in Australia and is in addition to (and does not exclude, restrict, or modify in any way) any non-excludable statutory warranties in Australia.
  3. During the Warranty Period Residentia Group or its ASR will, at no extra charge if your Appliance is readily accessible for service, without special equipment and subject to these terms and conditions, repair or replace any parts which it considers to be defective. Residentia Group or its ASR may use remanufactured parts to repair your Appliance. You agree that any replaced Appliances or parts become the property of Residentia Group. This warranty does not apply to light globes, batteries, filters or similar perishable parts.
  4. Parts and Appliances not supplied by Residentia Group are not covered by this warranty.

5. You will bear the cost of transportation, travel and delivery of the Appliance to and from Residentia Group or its ASR. If you reside outside of the service area, you will bear the cost of:
  - (a) travel of an authorised representative;
  - (b) transportation and delivery of the Appliance to and from Residentia Group or its ASR, in all instances, unless the Appliance is transported by Residentia Group or its ASR, the Appliance is transported at the owner's cost and risk while in transit to and from Residentia Group or its ASR.
6. Proof of purchase is required before you can make a claim under this warranty.
7. You may not make a claim under this warranty unless the defect claimed is due to faulty or defective parts or workmanship. Residentia Group is not liable in the following situations (which are not exhaustive):
  - (a) the Appliance is damaged by:
    - (i) accident
    - (ii) misuse or abuse, including failure to properly maintain or service
    - (iii) normal wear and tear
    - (iv) power surges, electrical storm damage or incorrect power supply
    - (v) incomplete or improper installation
    - (vi) incorrect, improper or inappropriate operation
    - (vii) insect or vermin infestation
    - (viii) failure to comply with any additional instructions supplied with the Appliance;
  - (b) the Appliance is modified without authority from Residentia Group in writing;
  - (c) the Appliance's serial number or warranty seal has been removed or defaced;
  - (d) the Appliance was serviced or repaired by anyone other than Residentia Group, an authorised repairer or ASR.
8. This warranty, the contract to which it relates and the relationship between you and Residentia Group are governed by the law applicable where the Appliance was purchased.
9. To the extent permitted by law, Residentia Group excludes all warranties and liabilities (other than as contained in this document) including liability for any loss or damage whether direct or indirect arising from your purchase, use or non use of the Appliance.
10. For Appliances and services provided by Residentia Group in Australia, the Appliances come with a guarantee by Residentia Group that cannot be excluded under the Australian Consumer Law. You are entitled to a replacement or refund for a major failure and for compensation for any other reasonably foreseeable loss or damage. You are also entitled to have the Appliance repaired or replaced if the Appliance fails to be of acceptable quality and the failure does not amount to a major failure. The benefits to you given by this warranty are in addition to your other rights and remedies under a law in relation to the Appliances or services to which the warranty relates.
  11. At all times during the Warranty Period, Residentia Group shall, at its discretion, determine whether repair, replacement or refund will apply if an Appliance has a valid warranty claim applicable to it.
  12. To enquire about claiming under this warranty, please follow these steps:
    - (a) carefully check the operating instructions, user manual and the terms of this warranty;
    - (b) have the model and serial number of the Appliance available;
    - (c) have the proof of purchase (e.g. an invoice) available;
    - (d) telephone the numbers shown below.
  13. You accept that if you make a warranty claim, Residentia Group and its ASR may exchange information in relation to you to enable Residentia Group to meet its obligations under this warranty.

**IMPORTANT**

Before calling for service, please ensure that the steps in point 12 have been followed.

Telephone contacts

- ▶ Service: Please call 1300 11 HELP (4357)

**The Australian Consumer Law requires the inclusion of the following statement with this warranty:**

Our goods come with guarantees that cannot be excluded under the Australian Consumer Law. You are entitled to a replacement or refund for a major failure and for compensation for any other reasonably foreseeable loss or damage. You are also entitled to have the goods repaired or replaced if the goods fail to be of acceptable quality and the failure does not amount to a major failure.

**An initiative by  
Residentia Group**



**T. 1300 11 4357  
E. support@residentiagroup.com.au**

**www.solt.house**



E2447

**SÔLT**